



**New Tech Machinery**

A MAZZELLA COMPANY

**Innovation. Quality. Versatility.**

*The World's Finest Portable Rollforming Equipment*



# SSH<sup>TM</sup> Roof Panel Machine

[www.GutterSupply.com](http://www.GutterSupply.com)

1-888-909-RAIN

[Info@GutterSupply.com](mailto:Info@GutterSupply.com)

# The World's Finest Portable Rollforming Equipment

## SSH™ MultiPro

### Light Commercial / Residential Multi-Profile Roof Panel Machine

- The high performance solution to your residential and light commercial needs.
- Seven available panel profiles in variable widths, multiple gauges and various material types



**Note:** Machine shown with optional equipment

#### STANDARD FEATURES

Polyurethane Drive Rollers	Powder-Coated Frame & Covers
Power Interruption Safety Circuit	Runs Up to 24 Gauge Steel
Hydraulic Drive & Shear	Length Control Limit Switch
<b>Included:</b> PLC Batch / Length Computerized Controller	Welded Tubular Steel Frame
<b>Choice of:</b> Quick-Change™ Profile Roller System	Push Button RUN/JOG Controls
<b>Choice of:</b> Quick-Change™ Power-Pack (Gas or Electric)	UL Rated Panels (Must Be Certified by UL for Recognition)
<b>Choice of:</b> One Pair of Bead, Pencil, Striation or V-Rib Rollers	Industry's Best Warranty

#### SPECIFICATIONS

<b>SSH PANEL MACHINE</b>	
Length	12' 10" (3.9m)
Width	5' (1.5m)
Height	4' 3" (1.3m) with Over Head Rack 2' 0" (.6m) without Over Head Rack
Weight	3,725 lbs. (1,700kg)
<b>SSH ON TRAILER</b>	
Length	17' 6" (5.3m)
Width	7' (2.1m)
Height	6' 3" (1.9m) with Reel
Weight	5,275 lbs. (2,400kg)
<b>COIL WIDTHS</b>	
14" to 24" (355mm to 610mm)	
<b>MAXIMUM COIL DIAMETER</b>	
32" (812mm) with the Overhead Reel Rack	
45" (1,143mm) with the Free Standing Decoiler	
<b>FINISHED PANEL WIDTHS</b>	
10" to 20" (254mm to 508mm) - Note: Variable Depending on Panel Profile	
<b>MATERIALS FORMED</b>	
Painted Steel	30 ga. to 24 ga. (.3mm to .6mm) (painted, galvanized, aluminized)
Painted Aluminum	.027" to .040" (.7mm to 1.0mm)
Copper	16 oz. to 20 oz. 3/4 Hard (.5mm to .7mm)
<b>SHEAR</b>	
Hydraulically Powered, Infinitely Adjustable, Hardened Tool Steel Blades & Shear Dies	
Panel Recognition Safety System	
<b>DRIVE</b>	
Hydraulically Driven via Chain, Sprocket & Gear	
<b>SPEED</b>	
60 ft./min (18.3m/min) Approx.	

# The World's Finest Portable Rollforming Equipment

## SSH™ Panel Profiles (Choice of)



These field formed panels have demonstrated compliance with UL580, Class 90 when a UL certificate accompanies the machine producing panel.

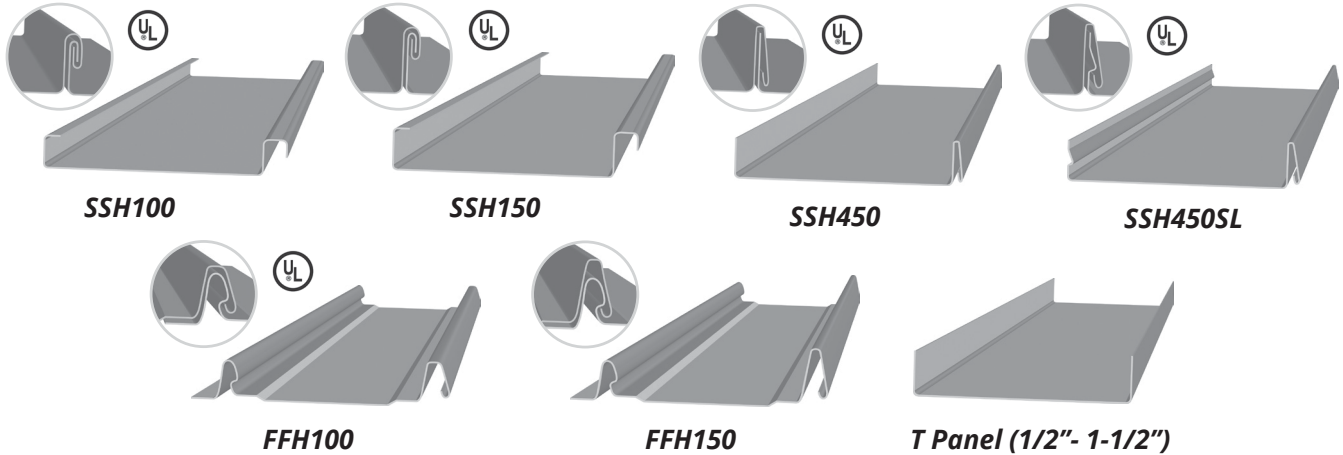

PROFILES	
SSH100 * †	1" high x 1/2" wide (25.4mm x 12.7mm) mechanically seamed panel. Includes a hand seamer and clip relief.
SSH150 * †	1-1/2" high x 1/2" wide (38.1mm x 12.7mm) mechanically seamed panel. Includes a hand seamer and clip relief.
SSH450 * / 450SL *	1-1/2" high x 1/4" wide (38.1mm x 6.4mm) snap clip panel / snap lock panel. Includes clip relief rollers.
FFH100	1" snap seam (25.4mm) with slotted fastener flange for clipless installation. Includes clip relief rollers and automatic "no chip" rotary slotter.
FFH150	1-1/2" snap seam (38.1 mm) with slotted fastener flange for clipless installation. Includes clip relief rollers and automatic "no chip" rotary slotter.
T-Panel	1/2" to 1-1/2" high (12.7mm to 38.1mm)

\* Can make T-Panel † Suitable for Zinc

All roller systems include shear dies and clip relief rollers.

- SSH100, SSH150 and SSH450/450SL Roller Systems all use identical left side roller sets.
- FFH100 and FFH150 also share identical left side roller sets.

If you purchase or own one of these roller systems, you can add any of the other right side systems *at a reduced price!*

**Warranty:** • Three years parts (including electrical) / Three years labor  
 • Limited lifetime separation on drive rollers  
 • Limited lifetime on stainless steel forming rollers

U.S. PATENT NO. 6,772,616

## Rib Roller Options



**CLIP RELIEF**



**BEAD RIBS**  
(STANDARD OR WIDE)



**PENCIL RIBS**  
(SMALL OR LARGE)



**V-RIBS**  
(SMALL OR LARGE)

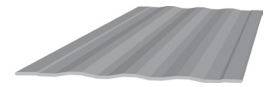

**STRIATION RIBS**

Innovation. Quality. Versatility.

*The World's Finest Portable Rollforming Equipment*

## The NTM Roof Panel Machine Family:

**SSQII™**



**SSH™**



**SSR™**

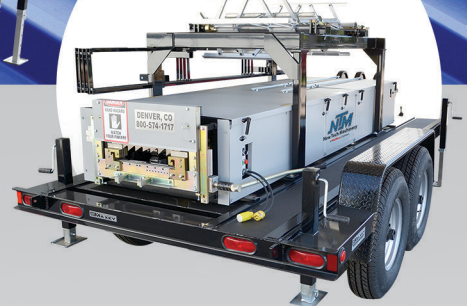

**5VC™**



Check Out the  
SSH Online:



**NTM**

New Tech Machinery

A MAZZELLA COMPANY

[www.GutterSupply.com](http://www.GutterSupply.com)

1-888-909-RAIN

[Info@GutterSupply.com](mailto:Info@GutterSupply.com)

© 2019. New Tech Machinery - 030619

Proud  
Members of:

